

Short List #1

Santa Monica Virtual Book Fair

September 30 - October 3, 2021



---

Peruse the Stacks

14308 42nd Ave Ct NW

Gig Harbor, WA 98332

(253)232-2745

[perusestacks@gmail.com](mailto:perusestacks@gmail.com)

**Roald Amundsen**  
Signed Card

[Norway] : [ca. 1925]. Beautiful blue ink signature from the great Norwegian explorer on a printed card, 3" x 1.5" in original secretarial addressed envelope. Ca. 1925, with Norway Scott 111 Crown Lion with Axe stamp, Oslo cancel. Very good with some browning and wear to card and envelope. Signature remains bright.

850

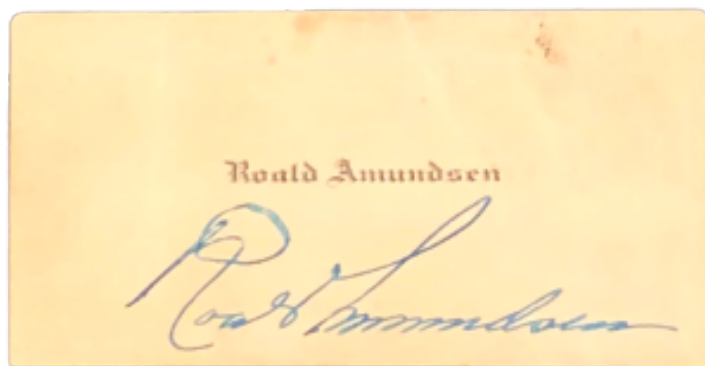

Karel Čapek  
Bílá Nemoc



Praha: Fr. Borový, 1937. First edition, 12mo, [8], 121pp., [5]. Publisher's printed wrappers with illustrated jacket by Otakar Mrkvička depicting an apocalyptic skeleton soldier on horseback. Very good with some wear at spine ends in good jacket with some rubbing and a bit of separation at folds, loss at spine ends, mainly heel, and some soiling to rear panel. Also included are a folded leaflet [4] and invitation, with perforated corner removed, from the eponymous film's premier on December 21st, 1937, both in fine condition.

Čapek's 1937 play, as with many of his other works, was forward looking and political in nature, with a fantastical premise. With Nazi Germany becoming increasingly aggressive on the Czech border, the play was "certainly a topical work, with an expression of both civic responsibility and political courage." (Ivan Klíma, Karel Čapek: Life and Work). Klíma describes the plot:

"A white plague, a sort of leprosy, appears and snowballs around the globe. The disease progresses very fast; over the course of a few weeks, the patient completely decomposes. The disease has one peculiar property: it attacks only people who have reached middle age, that is, those in relatively influential positions. The White Plague takes place in a nearby, unspecified totalitarian country which is at that moment preparing to begin a war against its neighbors. The country is governed by a field marshal who is surrounded by sycophants and revered by the masses."

A scarce copy in jacket with accompanying ephemera, of what is considered by Čapek expert, František Černý, to be "among the best of Čapek's works, in the company of the greatest works of world drama."

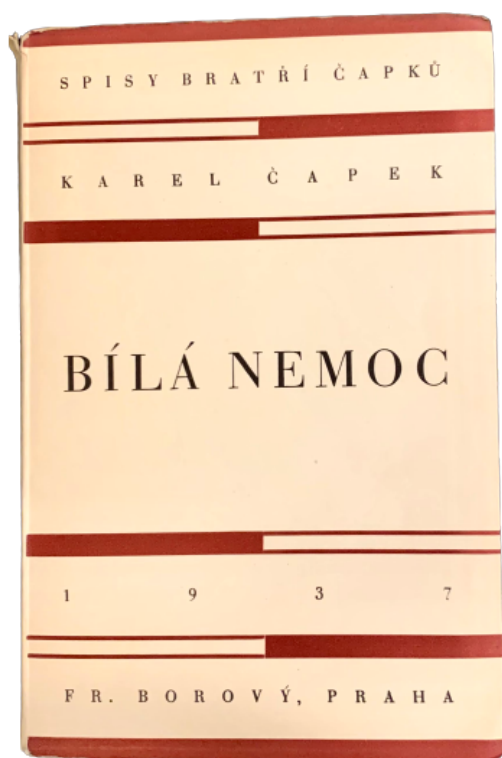

K A R E L Č A P E K

# BÍLÁ NEMOC

DRAMA O TŘECH AKTECH  
VE 14 OBRAZECH

1937

FR. BOROVÝ

PRAHA

## DIVADELNÍ HRY

Informace o provozování divadla ochotní podí Fr. Borový, Praha II., Národní 15

<p><i>František Čapek:</i> <b>ZE ŽIVOTA HMYZU</b> Komedie o 3 aktech s předehrou a epilogem. 7. vyd. Brož. Kč 15—, Váz. Kč 25—.</p> <p><i>Čapek Josef:</i> <b>DOBŘE TO DOPADLO</b> autob <b>TLUSTÝ PRADĚDEČEK, LOUPEŽNÍCI A DETEKTIVOVÉ</b> Dětská opera o dvou dějstvích s hudbou Jaroslava Křiváky. Libreto: brož. Kč 10—, váz. Kč 20—, Klavírní výtah Kč 50—.</p> <p><i>Čapek Karel:</i> <b>LOUPEŽNÍK</b> Komedie o 3 dějstvích. 5. vyd. Brož. Kč 15—, Váz. Kč 25—.</p> <p><b>R. U. R.</b> Kolektivní drama o vstupní komedii a o 3 dějstvích. 12. vyd. Brož. Kč 15—, Váz. Kč 25—.</p> <p><b>VĚC MAKROPILOS</b> Komedie o 3 dějstvích a příměsí. 6. vyd. Brož. Kč 15—, Váz. Kč 25—.</p> <p><b>BÍLÁ NEMOC</b> Drama o 3 dějstvích ve 14 obrazech. Brož. Kč 15—, Váz. Kč 25—.</p> <p><i>Klobouk Jan:</i> <b>ALADIN</b> Komedie o 2 dějstvích s doktron. Brož. Kč 15—.</p> <p><i>František Langer:</i> <b>JÍZDNÍ HLÍDKA</b> Hra o 3 děj. 5. výtah. Kč 15—.</p>	<p><i>František Langer:</i> <b>MANĚLSTVÍ S R. O.</b> Veselohra o 5 obr. Brož. Kč 15—.</p> <p><b>VELBLoud UCHEM JEHLY</b> Veselohra o 3 dějstvích. 4. vydání. Brož. Kč 15—.</p> <p><i>Nesvadba Vítězslava:</i> <b>MILENCI Z KIOSKU</b> Veršovaná komedie o 8 jednáních. Brož. Kč 20—.</p> <p><b>SCHOVÁVANÁ NA SCHODECH</b> Adaptace Calderonovy hry o 4 obr. Brož. Kč 40—, Váz. Kč 55—.</p> <p><i>Schejbalová Olga:</i> <b>HOUPÁČKA</b> Dětská veselohra o 4 aktech a 7 obr. Brož. Kč 15—.</p> <p><b>PAN GRÜNFIELD A STRAŠIDLA</b> Veselohra o 3 děj. Brož. Kč 15—.</p> <p><i>Srámek Fráňa:</i> <b>LĚTO</b> Hra o 3 dějstvích. Brož. Kč 15—.</p> <p><b>MĚSÍC NAD ŘEKOU</b> Hra o 3 dějstvích. Kč 15—.</p> <p><i>Fašovec a Worlich:</i> <b>KAT A BLÁZEN</b> Satirická fantazie o 10 obrazech. Kč 15—.</p> <p><b>NEBE NA ZEMI</b> Osvobozené divadlo o prologu a 11 obrazech. Brož. Kč 15—.</p> <p><b>RUB A LÍC</b> Ostinitická komedie o prologu a 19 obrazech. Brož. Kč 15—.</p>
--	---

U KNIHKUPCŮ - FR. BOROVÝ

Mož. nově vydáno. Pápařka v Brož.



MOLDAVIA-FILM

dovoluje si Vás zvát na slavnostní předvedení filmu

## BÍLÁ NEMOC

kteří se koná dne 21. prosince 1937 o půl 9. hodině večerní v bio ALFA

Moto věnců a kytcí věnovala společnost MOLDAVIA-FILM parádní dar pro věnovali nadšou nezaměstnaným

HEBE:

Dr. Golén	Hugo Haas
Maršál	Zdeněk Štěpánek
Prof. dr. Sigelius	Bařilich Karen
Baron Krog	Václav Vydra
Mladý Krog	Ladislav Boháč
Maršálůva dcera	Karla Oličová
Otec	František Smolík
Matka	Helena Friedlová
Syn	Vítězslav Boček
Dcera	Eva Svobodová
Malomocný	Jaroslav Vojta
První asistent	Vladimír Šmeral
Druhý asistent	Miroslav Svoboda
Maršálův adjutant	Otto Rubík
Ministr propagandy	Karel Dostál
Úřední pán	Rudolf Deyl

Lékaři, ošetrovatelé, nemocní, novináři, vojáka a davy.

REŽIE: HUGO HAAS

# The Caxton Club (James W. Ellsworth)

The Caxton Club: Officers, Committees, Constitution and By-Laws, Annual Reports, List of Members

Chicago: The Caxton Club, 1898. Limited to 300 copies printed in March, 1898. 16mo, [18], 83, [2] pp., publisher's brown cloth with red stamped Caxton Club logo on front and rear boards, gilt lettering on spine. Near fine with some darkening to spine and rubbing to edges and joints.

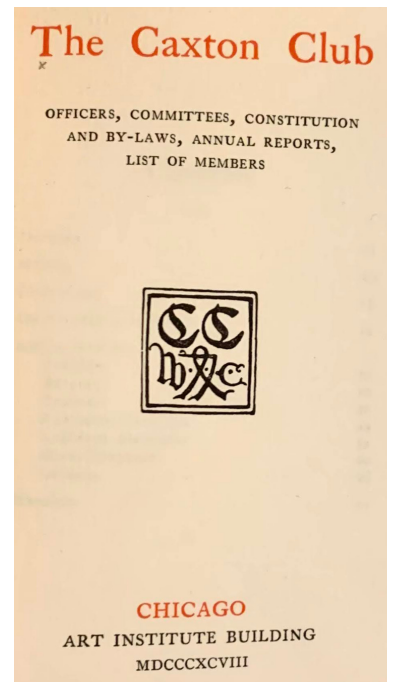
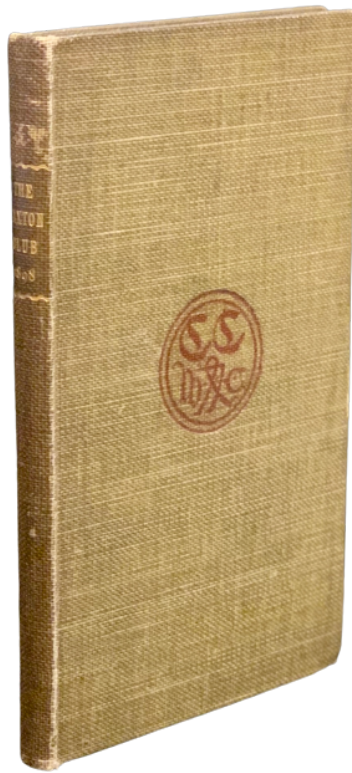

American coal baron, banker, and numismatist, James W[illiam] Ellsworth's copy, with his bookplate on the front pastedown. Ellsworth served as the Caxton Club's first president, and is listed as a member of the council in this early volume, printed three years after the club's founding. Ellsworth is also of note for bringing the first Gutenberg Bible to Chicago, the copy later passing through the hands of Rosenbach, and now found at the Scheide Library at Princeton University.

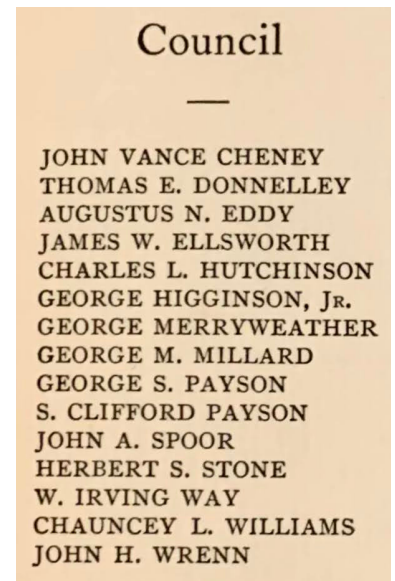

Substantial association copy of this early Caxton publication.  
Piehl 11

**Arthur A. Denny**  
**Pioneer Days on the Puget Sound**

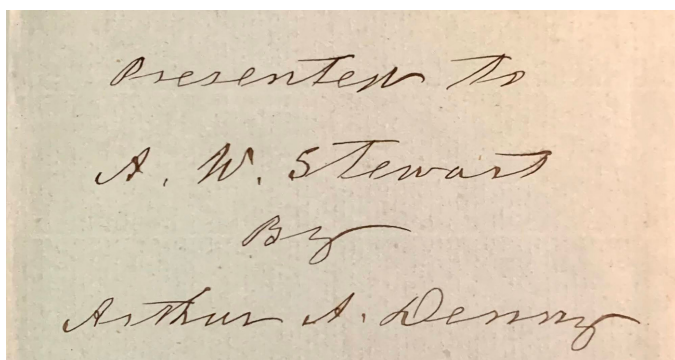
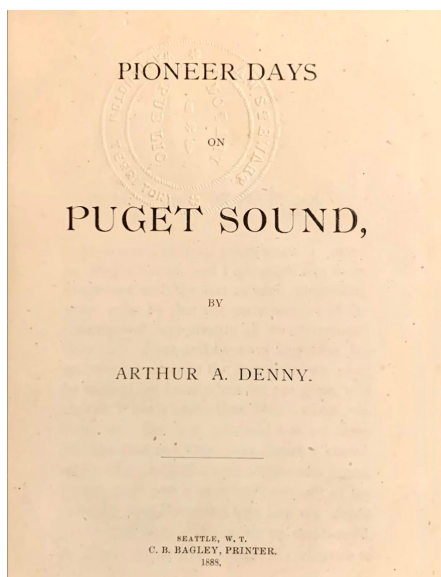
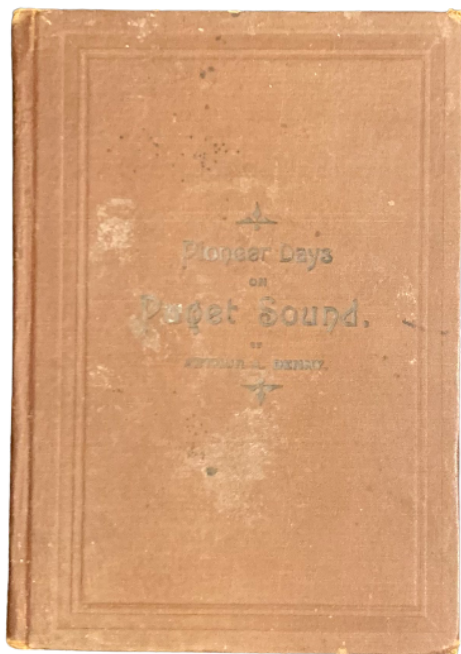

Seattle, W.T.: C. B. Bagley, Printer, 1888. First edition, 12mo, [3], 83pp., errata tipped-in at pg 83. Brown cloth with silver lettering and ruled in blind. Very good with most of the silver worn away and some staining and discoloration, mainly to rear board. Presentation copy, signed by Denny on the ffep, to A. W. Stewart, a notary public in W.T., the book containing several instances of his embossed stamp throughout.

The first-hand account of the founding of Seattle by the leader of The Denny Party, which left Illinois in the Spring of 1851 and arrived in the Puget Sound area several months later. The book describes in detail their journey, the claiming of land on Alki Point, securing supplies, the early saw mills, and much more. Only a small number of this volume were privately printed by Denny's friend and newspaperman, Clarence Bagley. As noted by Howes, "many copies [were] burned," presumably in the Seattle fire of 1889.

A scarce, and authoritative source on the early days of Seattle, presented and signed by Arthur A. Denny.  
 Graff 1053, Howes D253a, Smith 2408, Tweney 12

1950

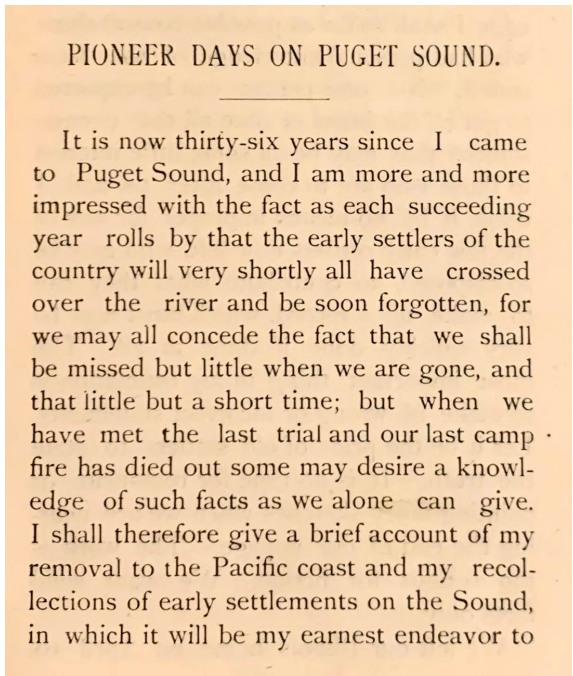

Todd Downing  
The Mexican Earth

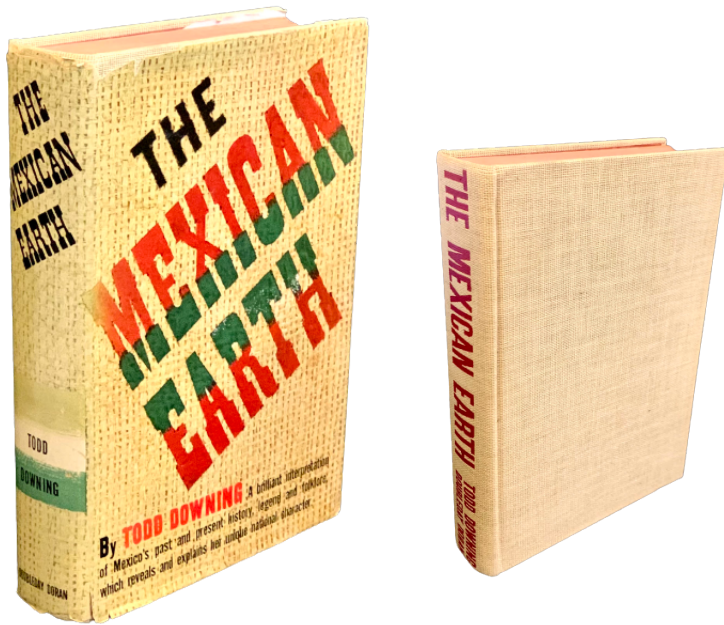

New York: Doubleday, Doran and Company, 1940. 8vo., 337 pp. Stated first edition of this travelogue of sorts from the mystery author of Choctaw descent, Todd Downing, and signed by him on the first blank page. Downing's works were murder mysteries set in Mexico, so the narrative history in this book was not a stretch, though it was his only foray into non fiction.

Near fine in tan buckram with red lettering to spine. Internally clean with some toning to foredge of page block and a small hole to upper corner of ffep. Jacket very good, price-clipped, with some wear and shallow loss at spine ends and corners, some sun fading to spine and toning to rear panel else nicely preserved.

1200

Sincerely,  
Todd Downing

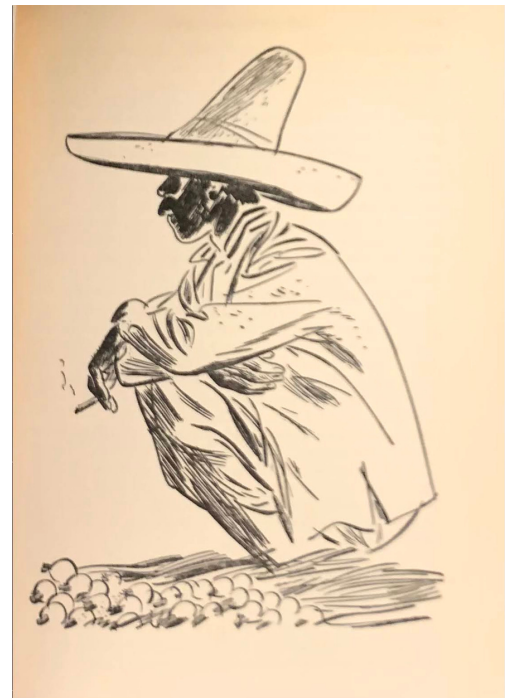
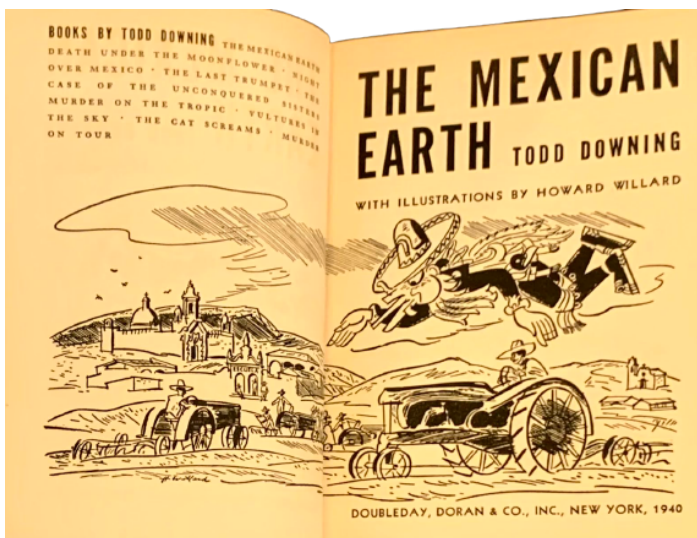

R. O. Evans  
The Tenderfoot's Moose Hunt

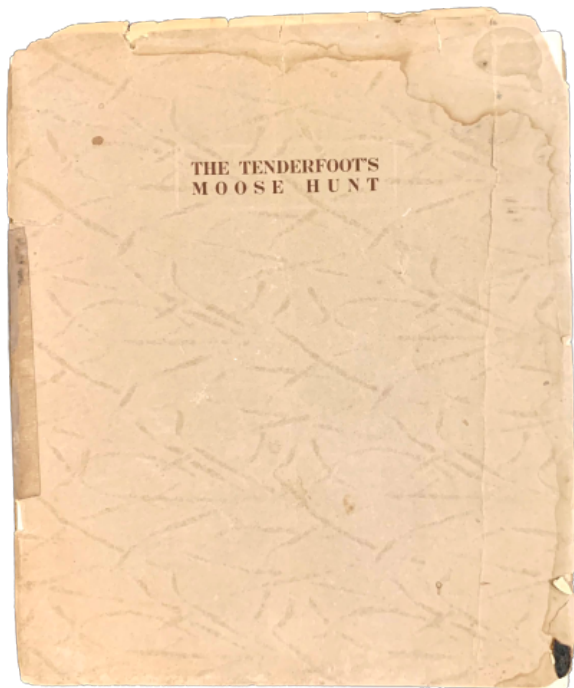

Chicago: Privately printed by the author, 1910. 8vo, 24 x 20cm, [2] 31pp. sepia photographs throughout, text printed in sepia with yellow borders. Patterned brown paper wrappers, saddle stitched. Good condition with tape along middle of spine, wrappers chipped and worn around edges. Some moisture staining to upper corner, foredge, throughout. Typed, signed cover letter from the author on his stationary from the Fisher Building, Chicago, laid in.

Marvelously illustrated account of a moose hunt in the wilds of Quebec, about 48 hours by rail from Chicago. The author and "Tenderfoot," R. O. Evans, Chicago investment banker, was accompanied by his friend and sportsman, Harry Vissering. Both men were members and directors of the Chicago Automobile club, and Vissering owned a railway equipment manufacturing company in the city. Their guide, a French Canadian, is described by Evans as having a dialect "not that with which Dr. [William Henry] Drummond has made us familiar in 'The Habitant' and 'The Wreck of the Julie Plant.'"

Evans' narrative is quite detailed, and very readable, with some self deprecating humor thrown in, constantly reminding the reader that he is but a tenderfoot.

Photographs are captioned and include particulars of the trip such as the journey by canoe, pictures of Vissering, Evans, and various guides, the trophies of a successful hunt, and the return voyage,

Overall, this is a nicely imagined and produced memento of a triumphant first moose hunt for the prominent Chicago businessmen. Likely quite rare, OCLC showing no holdings. Not listed in Phillips or Heller.

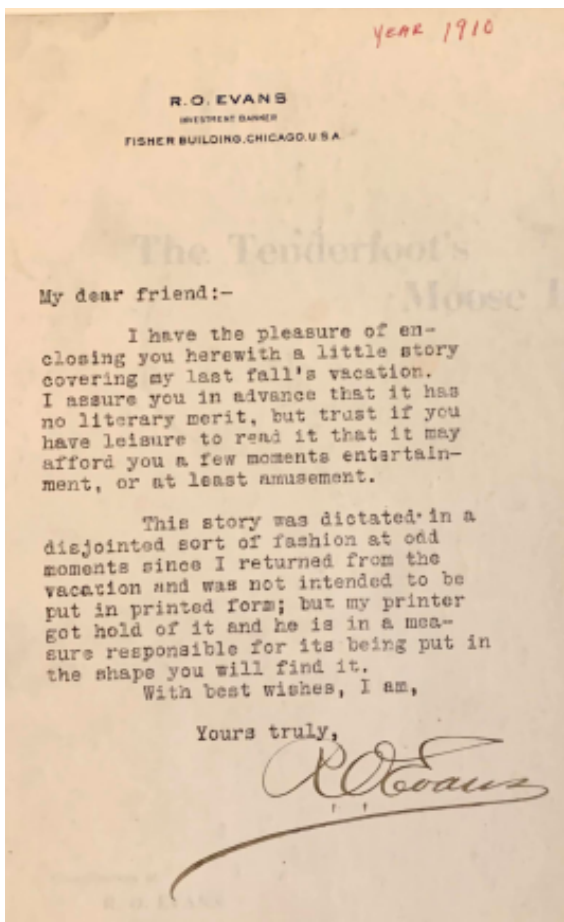



## The Tenderfoot's Moose Hunt

Compliments of  
R. O. EVANS  
CHICAGO

## THE TENDERFOOT'S MOOSE HUNT

The experiences of a tenderfoot will not interest the old-timer, except for purposes of criticism, and are therefore dedicated to the inexperienced who are hoping and perhaps expecting some day to go into the wilds after that monarch of the American forests, the Moose.

It may be here interpolated that these experiences are faithfully related; more acquaintance with the subject would doubtless have enabled the writer to better embellish the tale. No excuses are necessary for the frequent use of the personal pronoun, since the writer frankly admits that he is "The Tenderfoot" and that this story is the unvarnished report of his personal experiences.

A moose hunt has always been the one greatest desire, sportwise, of the writer's ambitions. For years he has looked forward to the time when he might see the fulfillment of his cherished dream. With the greatest avidity he has read of others' experiences in moose hunting and hung on the words describing the exploits of his friends who have tented in the great north woods.

Early in 1910 the tenderfoot's friend, that old-time sportsman, Harry Visering, of Chicago, agreed to accompany him. For months thereafter the trip was lived over in anticipation. The advice of friends was sought as to the proper outfit. From the lists thus secured about 90 per cent were eliminated and it was afterward found that we still had articles that might have been dispensed with. Experience teaches that all one should take on a trip of this kind is plenty of warm clothing, a sleeping bag, oiled hunting boots, a pair of good moccasins, together with rifle and ammunition. The other necessities your guide will

provide—but this is not keeping to the text. Let the old-timers advise.

Tickets were purchased and reservations made weeks in advance. Finally the day of departure arrived. Our baggage was O. K. 'd to its destination by the Canadian Customs Inspector in Chicago. The place we selected was one that on the railway maps appeared the farthest away from Quebec. Time tables told us we should reach it in forty-eight hours, but we were some four hours late and that is annoying when one is over-anxious. One wants to get into the woods, to taste the pleasures that he has so long anticipated, but which have up to now been denied him.

But all things have an end, and so did our journey. The head guide whom we had engaged some months before was at the station to meet us. He wasn't dressed as we thought he would be and didn't look nearly as much like a woodsman as either the tenderfoot or his companion in their regalia. The guide is a French Canadian and we wondered if he might not also have a touch of Indian blood in his veins. His dialect is not that with which Dr. Drummond has made us familiar in "The Habitant" and "The Wreck of the Julie Plant." His language and that of the other guides is a curious mixture, part English, part French, occasional Indian phrases, coined words, with expressions they have picked up from previous "sports" thrown in for good measure.

Our baggage was put in his wagon, after the courteous customs officer had released it, and we started for the official who issues the hunting licenses. These cost us \$50.00 each, good hard American dollars, and specify that each may kill one bull moose, one bull caribou and two deer. The natives' licenses cost but \$2.00 per man.

PAGE THREE



The Cook Shanty



The Tenderfoot's Partner



Mr. Vissering and Guides with the Record Moose Head



Bill and Uncle with the Tenderfoot's Trophy

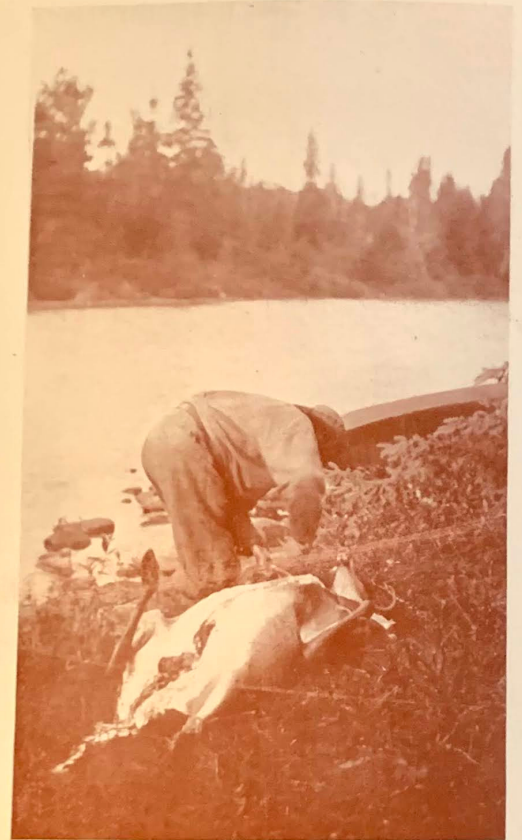

Fresh Venison

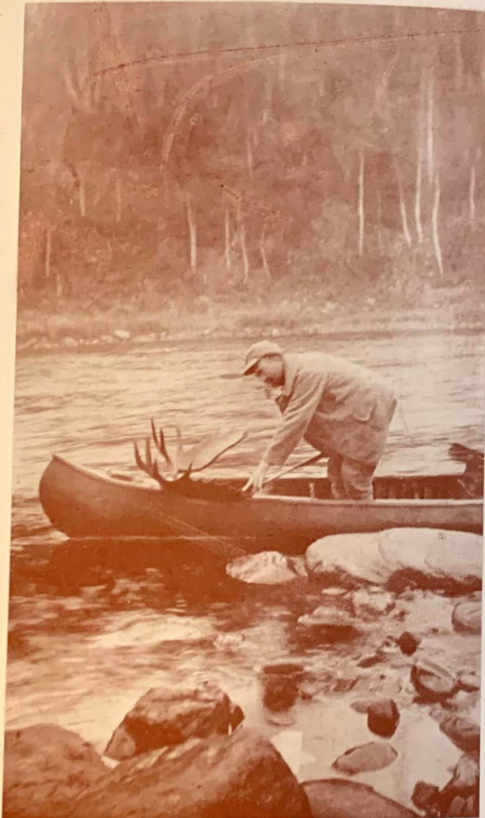

Loading the Canoe

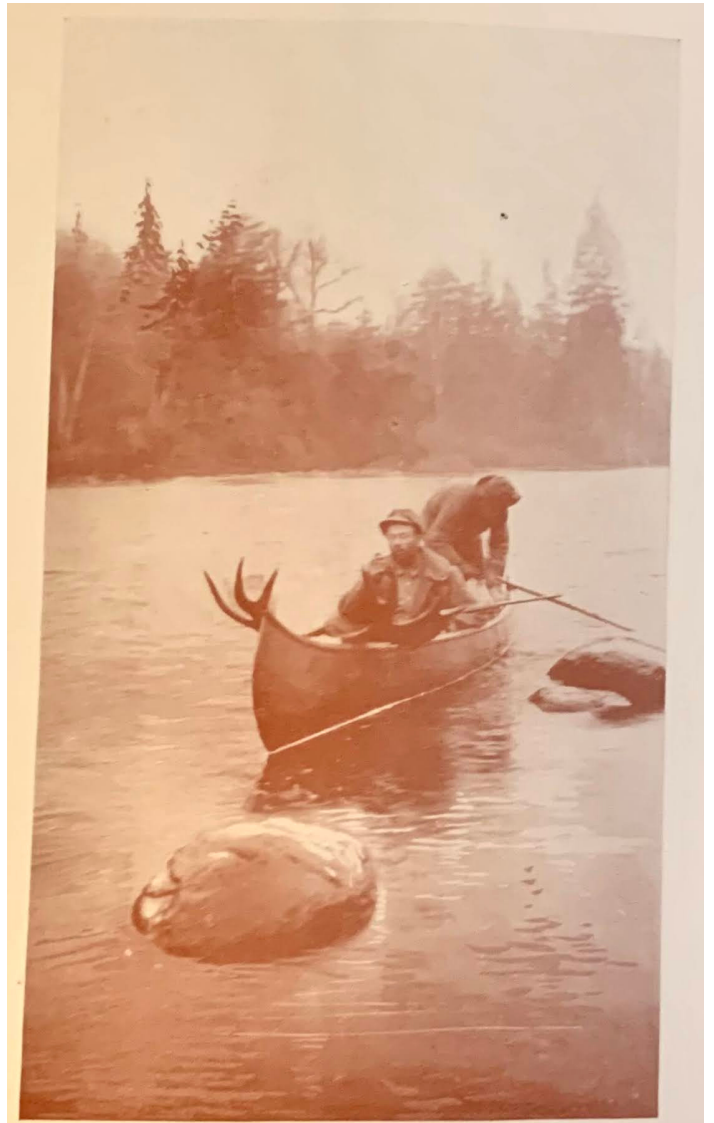

Homeward Bound



A Horseless Carriage in Acadia

# Zane Grey

Notes: Avalon --- Aug. 1916



Aug. 6.  
We went off Seal Rocks and trolled about five miles out.  
We met a sand-dabber who said he had seen a big broadbill back a ways. So we turned round. After a while I saw a big vicious splash half a mile east, and we made for it. Then I soon espied the fish.  
We worked around him a while, but he would not take a barracuda or a flying fish.  
It was hard to keep track of him on account of rough water. Soon he went down.  
Then a little later I saw <sup>what they called</sup> a Marlin. He had big flippers wide apart. I took him for a broadbill.  
We circled him, and before he saw a bait he leaped twice, coming about half out with belly towards us. He looked huge, but just how big it was impossible to say.

Avalon---Aug. 1, 1916.  
Took Dustin Farnum fishing. There was a haze and a sea that looked like wind. We trolled up to Long Point and then to the Isthmus. Saw no fish of any kind. The sea grew rough, with long rollers and white caps.  
About two o'clock I had a strike. Hooked the first, and for a little while had expectations. But the strain eased and presently I knew I had a shark. Upon bringing him to gaff found him to be a blue shark about 8 feet long.  
The wind grew stronger, so we quit for the day.

Avalon, CA: 1916. Typescript of Zane Grey's sportfishing logbook for an expedition with silent film actor, Dustin Farnum, with holograph corrections in original stamped mailing envelope.

63 unnumbered, typed pages, cover page blind stamped with Grey's ownership mark, on ruled paper, 8.25" x 4.5," brad bound at top. Several corrections and annotations in Grey's hand. Very good with some light chipping and wear to edges and around brads. Envelope stained and worn.

Daily log entries start on August 1st and end on September 14th, 1916. Grey's companion for the trip was film star, Dustin Farnum, who would go on to play in "The Light of Western Stars," based on the eponymous Grey novel. The logbook includes a few great narrative entries that span several pages, including dialogue and detailed descriptions of fish, gear, environs, and the thrill of the hunt.

Grey would later use these notes to put together several magazine articles:

- "Some Rare Fish of the Sea," Recreation, Oct. 1916
- "Sailfish," Recreation, Dec. 1916
- "Two Flights with Swordfish," Recreation, Oct. 1917
- "Gladiator of the Sea" Field and Stream, Apr. 1918
- "Avalon the Beautiful," Field and Stream, May 1918.

A captivating look at the sporting side of Grey's writing, with a link, through Farnum, to the Western genre for which he was most well-known.

# The Brothers Grimm

## Little Brother and Little Sister and Other Tales

London: Constable and Company Ltd., 1917. Limited to 525 copies signed by Arthur Rackham, this being #205. Large quarto, [iv] xi [xii] 251 [1] pages. 3/4 deep red morocco with marbled cloth boards and endpapers, all page edges and lettering in gilt and stamp-signed "Putnams," on the inside, rear cover. This copy has the extra, signed plate from Rackham bound in as well as the cloth covering for the original boards: front with label, rear, and backstrip with gilt lettering all attached to their own separate pages. Near fine with some light rubbing to corners and spine ends.

2500

ILLUSTRATED BY  
ARTHUR RACKHAM

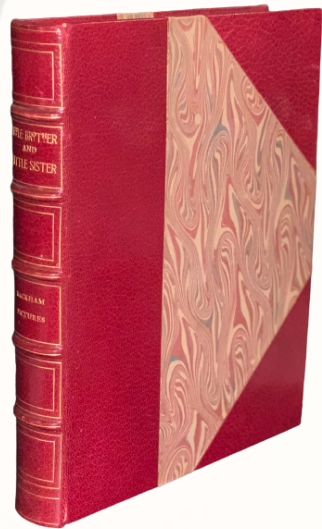
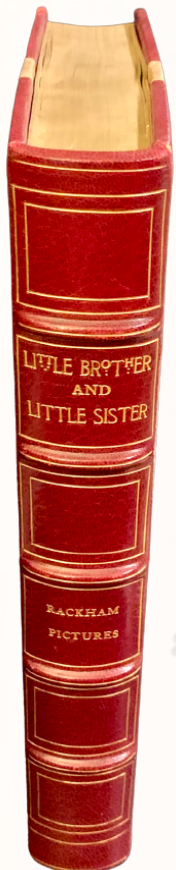

*This Edition is limited to 525 numbered and signed copies*

No. 205

*Arthur Rackham*

Kathleen Hale

Orlando the Marmalade Cat: A Camping Holiday

New York: Charles Scribner's Sons, 1938. First American edition of the first book in the successful children's book series, "Orlando The Marmalade Cat," by the British artist and author, Kathleen Hale. The series consisted of 19 books, the last being published in 1972.

Folio, very good in publisher's pictorial paper covered boards with some toning and foxing along spine and some light staining to bottom edges of boards. Endpapers show acid offsetting, else clean internally. Jacket very good with light chipping to heel of spine and bottom edges of front and rear panels. Some soiling to front and rear panels with rubbing to spine and along folds. Original price of \$2.50 in tact on front flap.

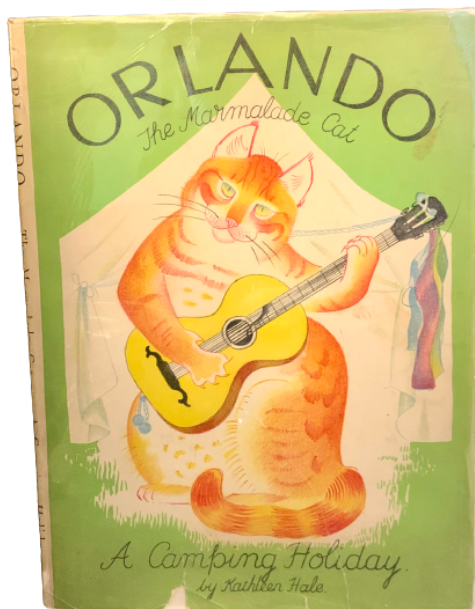

800

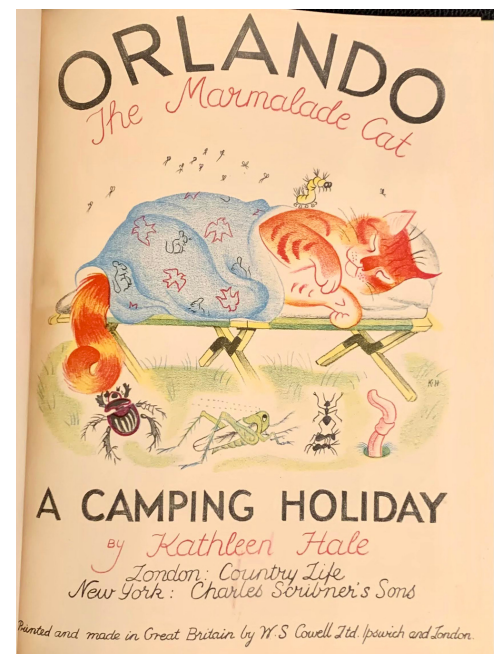

## Lanston Monotype Machine Co.

The Monotype Parts and Accessories: A List of Parts with Prices for Casting Machine and Keyboard and (herein lies the value of this book) Directions which, if Followed, Will Insure Our Customers Receiving the Parts Wanted

Philadelphia: Lanston Monotype Machine Co., [ca. 1909].

Early Lanston Monotype parts list, 16mo, paginated in sections for corrections 2pp., the casting machine 104pp., the keyboard 31pp., the mold 3+3pp., and miscellaneous 10pp.

Brad-bound on top edge with folding brown/olive cloth covers and black lettering. Very good, well-used copy with cloth worn and frayed at corners and along edges, and soiling to several pages. Label of The Eagle Printing Co., Santa Fe, New Mexico attached to front pastedown, and a few ownership markings in pencil from an Archie J., perhaps better known as "Fra Archibaldus," as is written on the title page.

This copy collated same as the Internet Archive copy (missing pgs. 101-102 of the caster section, perhaps never included) contributed by Dr. David M. Macmillan, however also including the following, inserted by the previous owner in various places throughout the pagination:

Letters, Figures and Points, and Extras list

Unit/Matrix Case Arrangements: 6N2 (2), Job Arrangement C2 (3), Book Arrangement C(2), German Arrangement C, Job Arrangement C1, Job Arrangement No. 7C1 Seven Alphabets, Job Arrangement No. 6C1 Six Alphabets, Job Arrangement No. 6C2 Six Alphabets, Arrangement 6N1 Set Sizes for 18 and 24 Point No. 25 Monotype Display Type Bulletin No. 2007: Low Quad Adjustments For All Type Molds factory repair order form

Scarce, important, and shop-used copy of this piece of printing history

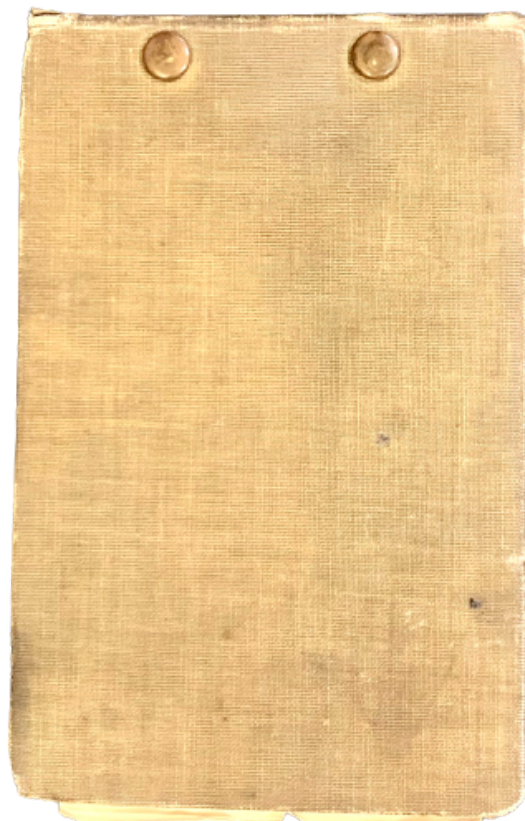
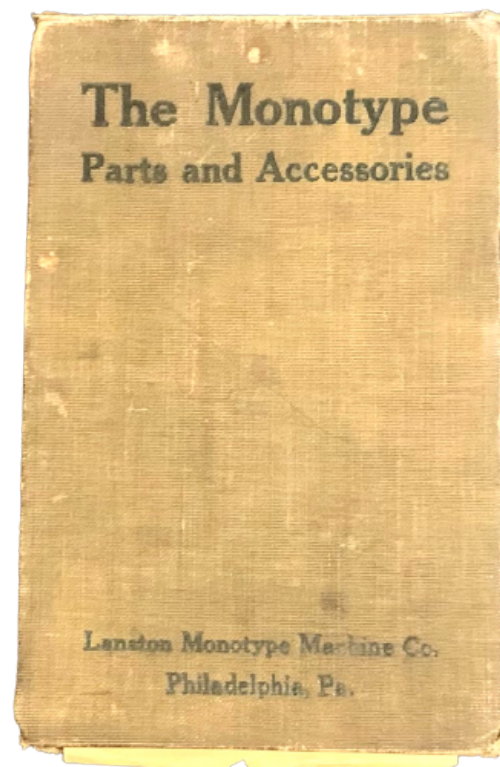

# The Monotype

## PARTS AND ACCESSORIES

A LIST OF PARTS WITH PRICES  
FOR  
CASTING MACHINE AND KEYBOARD  
AND  
(herein lies the value of this book)  
DIRECTIONS  
WHICH, IF FOLLOWED, WILL INSURE  
OUR CUSTOMERS RECEIVING  
THE PARTS WANTED



FRA ARCHIBALDUS

Philadelphia, Pa.  
LANSTON MONOTYPE MACHINE CO.  
No. 1231 Callowhill Street

## DEDICATION

**T**O all Monotype users we dedicate this book, hoping that it will not only eliminate mistakes in filling orders, but also enable our early customers to bring their machines up to date.

Its "authors," sanguine men, are hopeful that you will read the directions in the following pages, for if these be not read they have "authored" in vain and this perpetual list of parts will not realize the ambitions of its creators and "fill a long-felt want."

### DIRECTIONS

**F**OR convenience in symboling, the CASTING MACHINE is divided into eight groups of parts, these groups being lettered from A to H, inclusive. Each of these groups performs a different function; for example, the A group comprises the mechanism for carrying the MATRICES and holding the MATRIX over the opening in the MOLD while the type is being cast. Similarly, the KEYBOARD is divided into three groups, lettered K A, K B, and K C, respectively, each of which performs its separate function.

The groups are divided into sections, each section containing one or more pieces which, for convenience in ordering, are naturally grouped together. The different sections in each group are numbered from 1 up, this number being placed in front of the letter designating the group. The separate pieces in each section are numbered from 1 up on the Style D KEYBOARD list, while on the other lists the first piece in the section takes the section number and group letter only. The piece number is placed after the letter designating the group. Thus, referring to page 1 of the CASTING MACHINE list, the symbol of the BRIDGE LEG is I A 2. This denotes that it is piece number 2 in the first section of the A group.

For accuracy in manufacture, it is necessary, in some cases, to furnish two or more pieces together. Such pieces are indicated by a Roman figure 1, placed one em leader to the left of the right end of the leader line. While some of the major pieces cannot be furnished without their minor pieces, the minor pieces may often be furnished without the major pieces. In such cases, the major piece will have a Roman figure 1 one em leader to the left of the right end of the leader line, and the minor pieces will have an Italic figure (i) in parentheses in the same relative position. For example, referring to the A group of the CASTING MACHINE, the BRIDGE 1A and the BRIDGE LEG 1A2 cannot be furnished SEPARATELY, AND SCREWS 1A3 AND 1A4 AND SCREWS 1A5 AND 1A4 and the BRIDGE PIN 1A10 must always be furnished when the BRIDGE is ordered, but may be furnished separately if required; this is indicated by the Italic figure (i) in parentheses. The price of \$30.00 given on the same line with the BRIDGE 1A includes all the pieces that must be furnished with it, namely, the BRIDGE LEG 1A2, SCREWS 1A3 and 1A4, and PIN 1A10. Since the BRIDGE LEG cannot be furnished separately, no price is given for it, but a price is given for the SCREWS 1A3 and 1A4 and PIN 1A10, in case they should be required separately.

In some instances, a section contains two or more independent assembled parts, each of which is made up of pieces that must be furnished in combination, but any one of the assembled parts may be furnished independent of the others. To distinguish between these independent assembled parts, Roman and Italic figure 1's are used for the first part, figure 2's for the second part, etc.

In the case of the Style D KEYBOARD, an improvement has been made in listing the parts that must be furnished together, which, in conjunction with the system described above, works for clearness and accuracy. Each section containing parts that must be furnished assembled is followed by one or more notes which state clearly what pieces must be furnished together and gives the price of the assembled parts. To call attention to the note, the symbol of the major piece is altered by placing the letter K after the piece number, and the price is omitted. Since the minor pieces can be furnished separately, a price is given for them following their respective symbols in the section, but these prices are put in Italic to indicate that they are included in the price of the major piece given in the note below; therefore, in adding the prices of the individual pieces of a section to find the price of a complete section, omit all prices in Italic.

To order all of the pieces of an assembled part, it is necessary only to give the name of the major piece and its symbol (being careful to include the extra letter which follows the piece number in the case of the Style D KEYBOARD). All the minor pieces will then be furnished assembled with the major piece. Do not specify the minor pieces in your order or an extra set of these will be sent in addition to the set assembled with the major piece.

To order all of the pieces of a section, it is necessary only to give the name of the main piece followed by its symbol and the

### LOAN MATERIAL

**T**HE Monotype has been well called "the always-busy-machine." Because of its flexibility, the ease with which it handles all classes of composition and its efficiency as a type caster, it eliminates "idle time."

We recognize that the stoppage of so important a part of a printing-office is a serious matter. We cannot build a machine that is proof against accidents, but we can and do use every effort to make repairs as quickly as possible.

As the principal expense for repairing highly productive machinery is not the cost of the parts required, but the time lost making repairs, we have arranged to reduce this time to the minimum by lending our customers parts for use while they return theirs to us.

To make this plan a success this loaned material must be returned to us promptly upon receipt of the repaired material. The loan of this material is an accommodation and its prompt return is necessary if other customers are to be accommodated. To put this in dollars and cents: We charge only a small fixed fee for the use of loan material, and then a daily rental for the detention of the loan material after the receipt of the repaired material.

The parts which we will loan together with the fixed fees and daily rental charges are as follows:

	Fixed Fee	Daily Rental
MOLD	\$4.00	\$1.50
CAM SHAFTS (60)	5.00	1.00
NORMAL WEDGES	1.00	.50
Regular Wedges, we charged loan Special Wedges.		

This daily rental begins on the day following the receipt of the repaired part by the customer. Therefore our material should be shipped back to us on the same day that the customer receives his own material. The customer pays transportation charges in both directions on loan material and on repaired material. All shipments of loan material must, of course, be made by express.

### Corrections in Price List Monotype Parts and Accessories October 1, 1911

To keep your copy of our Price List up to date, please make the following corrections NOW.

**CASTING MACHINE, page 3:**  
Change the symbol of CENTERING-PIN-STAND BUSHING from 6A5 to a6A3.

**CASTING MACHINE, page 12:**  
Strike out the TYPE-SUPPORT-SPRING-BAR STUD B31B (in the section inside the border), as this is made a part of the BAR C31B.

**CASTING MACHINE, page 15:**  
Strike out the MOLD-BLADE-ADJUSTMENT-SLIDE-ANVIL DOWEL (2) 14C4, as these are no longer furnished.

**CASTING MACHINE, page 25:**  
Change the symbol of the BELT-SHIFTER-ARM SET SCREW from 2S2 to 2S3.

**CASTING MACHINE, page 34:**  
Change the price of the LOCKING-BAR-BELL-CRANK STUD B32E (in the section inside the border) from \$9.40 to \$9.15.

**CASTING MACHINE, page 35:**  
Strike out the LOCKING-BAR CAM B5E, as we no longer furnish this BAYTON CAM but furnish instead the wide CAM B5E (see Improvement No. 2).  
Change the quantity of LOCKING-BAR-LEVER-LINK PIN 34E from (1) to (2).

**CASTING MACHINE, page 45:**  
Change the section beginning "WORM SHAFT" to read as follows:

WORM SHAFT	80E	15.00
gear	(i) 80E1	4.50
hand wheel	(i) 80E2	5.00
key (for Worm)	(i) 80E3	.05
" (long for Gear and Hand Wheel)	(i) 80E4	.05
nut	(i) 80E5	.11
worm	(i) 80E6	3.50
WORM SHAFT 80E (complete)		15.71

**CASTING MACHINE, page 67:**  
Change the price of the PIPE BRACKET a16H as follows and note that the SCREEN a16H4 has been added:

PIPE BRACKET	a16H	2.50
screen	a16H4	.10
screen (large)	(2) a16H1	.08
screen (small)	a16H3	.03
PIPE BRACKET a16H (complete)		2.81

(Corrections 1)

### SET SIZES FOR 18 POINT NO. 25 MONOTYPE DISPLAY TYPE

For width of characters and the WEDGES (with their positions) to produce these set-sizes see below. The left column is for machines with WEDGES 178 to 203 inclusive; the right for machines with WEDGES 428 and 478. The standard for this face 1037 has by Cap II, 10 uni line up for each character, but use care in changing the MATRICES in the MOLD to obtain so being each character to its true position. Before returning the MATRICES lock up one type of each character and take a press proof to see the alignment.

WEDGE No.	TYPE POSITION	CHARACTER	WEDGES	TYPE POSITION
178 (10)	100	l	178	100
178 (11)	101	l	178	101
178 (12)	102	l	178	102
178 (14)	104	l	178	104
178 (15)	105	l	178	105
188 (1)	106	1 2 3 4 5 6 7 8 9 0	188	106
188 (2)	107	a b c d e f g h i j k l m n o p q r s t u v x y z	188	107
188 (3)	108	z h i k n u y	188	108
188 (4)	109	s e	188	109
188 (5)	110	c	188	110
188 (6)	111	o o q	188	111
188 (7)	112	b h f l	188	112
188 (8)	113	d p t	188	113
188 (9)	114	a u y y	188	114
188 (10)	115	h k n r x w	188	115
188 (11)	116	e	188	116
188 (12)	117	m	188	117
188 (13)	118	n	188	118
188 (15)	119	w	188	119
188 (20)	120	e o	188	120
188 (4)	121	e o	188	121

\* NORMAL-WEDGE PACKING PAPER 478S must be in position on the NORMAL WEDGE 478 to obtain this set-size.

34-11-06-2M-3

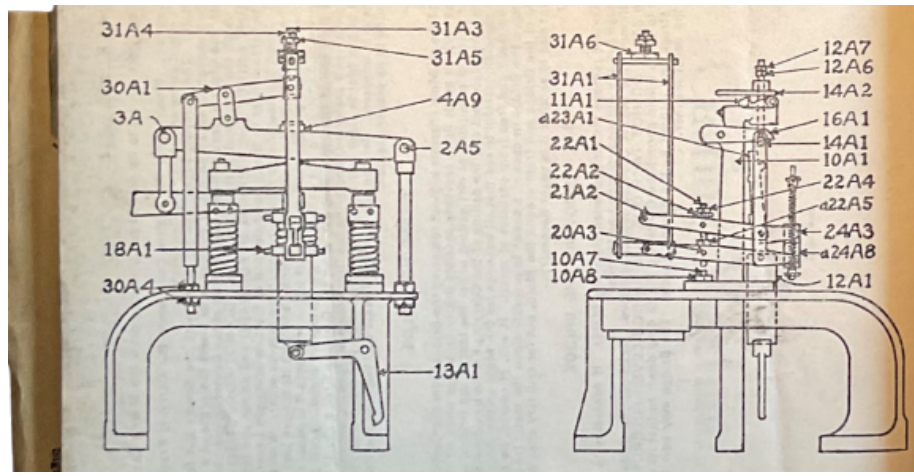



F r o m  
**The EAGLE Printing Co.,**  
 Santa Fe, New Mexico

*The Mono System*  
 Harry Adams

LOWER CASE	CAPS	FIGURES AND POINTS	EXTRAS
A		\$	fl
B		1	ff
C		2	ff
D		3	ff
E		4	ff
F		5	ff
G		6	ff
H		7	ff
I		8	ff
J		9	ff
K		0	ff
L			
M			
N			
O			
P			
Q			
R			
S			
T			
U			
V			
W			
X			
Y			
Z			
&			

A .....  
 Lbs. ARRANGEMENT  
 PL .....

### Arrangement 6N2

Roman caps and lower case; Boldface caps and lower case; Italic caps and lower case; Roman and Boldface figures, and two-line price figures

Unit value	Row	A	B	C	D	E	F	G	H	I	J	K	L	M	N	O	Row
5	1	:	;	l	t	'	,		l	i	:	;	'				1
6	2	;	?	j	f	t	i	-	j	f	•	?	.	,	l		2
7	3	(	)	-	j	f	r	e	s	r	s	t	c	v	z	q	3
8	4	x	k	y	s	I	r	t	o	I	z	c	e	I	b	g	4
9 <sup>a</sup>	5	d	h	9	7	5	3	1	0	.	9	7	5	3	1	0	5
9 <sup>b</sup>	6	a		p	8	6	4	2	\$	-	\$	8	6	4	2		6
9 <sup>c</sup>	7	S	z	x	v	c	e	x	J	g	o	a	q	y	v	J	7
10	8	S	a	o	g	y	p	u	n	k	b	h	d	J	n	u	8
11	9	L	F	S	q	p	b	d	k	G	C	O	B	R	C	P	9
12	10	E	P	L	F	E	n	T	w	L	P	F	V	Y	h	u	10
13	11	V	&	Q	V	C	B	T	O	E	A	w	T	A	B	C	11
14	12	A	R	N	D	o	w	m	Y	Ü	G	R	U	Y	D	Q	12
15	13	G	K	K	X	X	N	D	N	K	H	m	H	H	U	&	13
18 <sup>a</sup>	14	<b>0987654321\$<sup>m</sup>MW<sup>w</sup></b>															14
18 <sup>b</sup>	15	<b>0987654321\$<sup>M</sup>MW<sup>■</sup></b>															15

712a-2M  
 10-11F  
 A B C D E F G H I J K L M N O  
 With this arrangement use S15 Stopbars and corresponding Wedges; Left and Right Keybanks 6N1 and Left Keybar 6N1, Right Keybar 6N2

### SUMMARY

**D**ON'T assume that you know how to use this Price List until you have read the directions and this summary. A few moments thus spent will save delays that are always annoying and usually costly.

First, determine the number of the machine for which the piece is required and state this number on your order.

Second, find the desired piece in the Price List and give its name and symbol accurately. Use the Plate Books in conjunction with this Price List.

Third, when a section in a border follows the section containing the piece desired, note from the number of your machine whether to order from the border section or from the standard section.

Fourth, if this improvement has not already been applied to the machine in question and if you desire to bring it up-to-date, see the blue sheet for this improvement and order all parts for "Improvement No. 10" for example. When you apply an improvement to one of your machines note on this improvement sheet the number of the machine and the date on which the change was made.

Fifth, if your copy of this Price List contains pink sheets always refer to them before making out your order.

# Arthur St. John Newberry

## Another Catch: More Fugitive Notes on Sport and Other Things

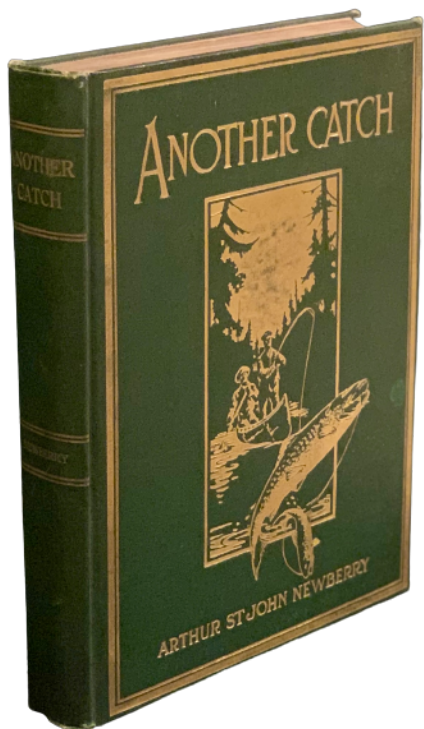

Cleveland: Printed for the Writer by the Bryan Printing Company, 1914. First edition, No. 11 of 75 copies, presented to Annie Wright Jaggard. 8vo, 21 x 16.5 cm, [17], 280pp, [1], black and white photos, one in color, chapter initials, tailpieces, and cover design by Lionel C. Humphrey, Green cloth with gilt stamped illustration and lettering on front cover and spine. Near fine with some wear at spine ends and corners, and dulling to spine. First two blank pages corner-clipped, else clean internally.

Published posthumously and presented by his widow, contains chapters by Newberry on his youth, experiences in fresh and salt angling, hunting deer, political views on labor, workers compensation, Roosevelt, and others.

### Contents

The Conduct of a Sportsman	- - -	17
Boyhood Days	- - -	21
Some Dogs	- - -	47
Hunting the Deer	- - -	67
Firearms	- - -	79
A Fisherman's Paradise	- - -	95
Trouting	- - -	117
On Lines	- - -	145
Trouble in the Tropics	- - -	155
More Lines and More Trouble	- - -	173
Up in the Air	- - -	185
Portraiture for Amateurs	- - -	193
A City Garden	- - -	201
Poetry and Verse	- - -	207
A Welcome Back	- - -	209
An Engagement	- - -	211
More Serious Subjects	- - -	215
The Price of Labor	- - -	217
Insurance Against Strikes	- - -	227
Is Roosevelt a Menace to Industry?	- - -	239
Compensation for Injuries to Workmen	- - -	241
A Reformed Medium	- - -	261

Heller 583, Wetzel pg 187

925

This book, published after the death of the author, is  
*No. 11*  
of a limited edition of seventy-five copies,  
and carrying out his wishes, is presented  
by his widow to

*Annie Wright Jaggard-*  
in his memory.



*Freshly Caught Dolphin*

# Sperry Univac Defense Systems

The Collected Adventures of Tom Swift Among the Old Crows: Tom Swift and His Electrological Sensotometer; Tom Swift and His Wizard Brain

St. Paul: Sperry Univac Defense Systems, [1966]. Set of two promotional brochures in slipcase for Electronic Warfare systems from Sperry Univac, ca. 1966. Both brochures and slipcase decorated with the original cover illustration for the Tom Swift novels by Victor Appleton. One is single sheet, tri-fold, the other staple-bound, both housed in paper slipcase, 8.5" x 11." Laid into "Electrological Sensotometer," is an electromagnetic spectrum frequency and metric wavelength chart. In rear pocket of "Wizard Brain," is a yellow paper invitation offering further information in the form presentations by company representatives. Some moisture staining to upper gutter of "Wizard Brain," and some soiling to slipcase, else fine and clean.

Marvelous advertising material from Sperry Univac Defense Systems marrying the Tom Swift aesthetic with their technological developments in electronic warfare systems during the Cold War era. Each brochure contains a frontis illustration, by Gary Kelley, presumably original to this publication. The illustrations are accompanied by quotes and page numbers from each title: "'And now, gentlemen,' said Tom revealingly, 'here is the device that will make America safe from the electronic perils of its foes!' -Pg 76 Tom Swift and His Electrological Sensotometer." "Tom Swift and His Wizard Brain," even contains a sample chapter titled, "Flashing Lights." The rear folder mentions an information unit complete with overhead slide transparencies, which are not present.

Unrecorded in OCLC, with little to no information to be found elsewhere on this scarce advertising material.

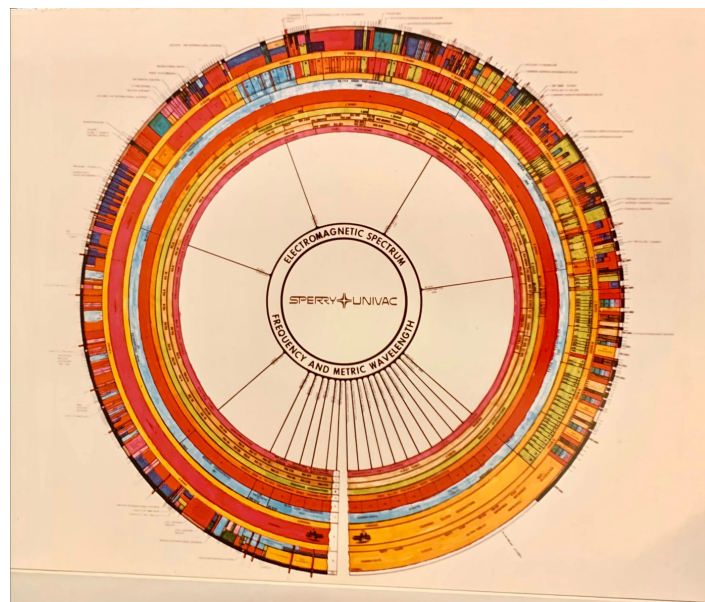
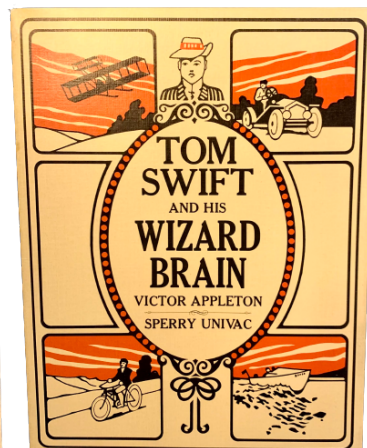
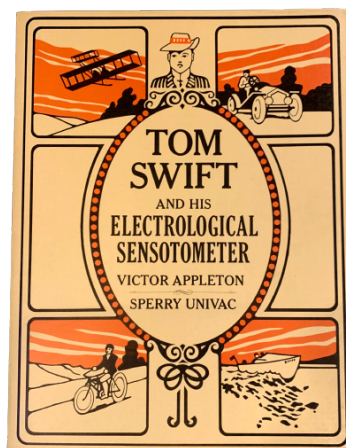
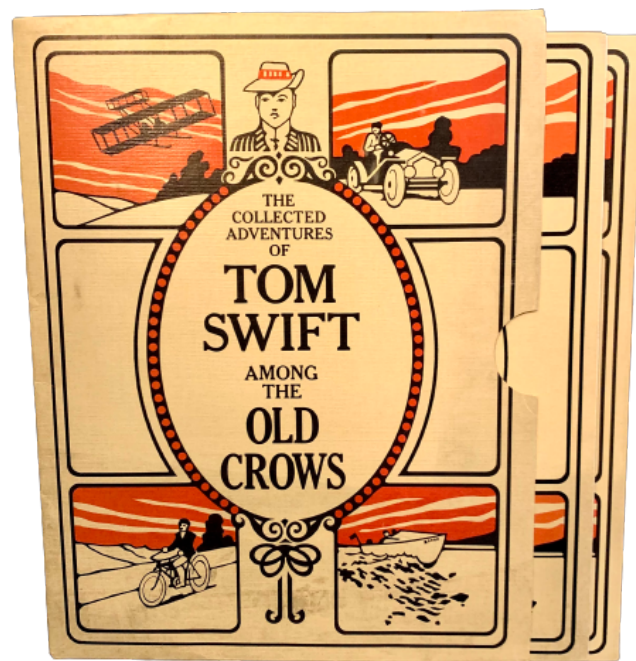

# TOM SWIFT AND HIS WIZARD BRAIN

## CHAPTER I

### FLASHING LIGHTS

"Well, Tom, I've never seen the like!"

Mrs. Baggert, Tom Swift's housekeeper, raised her feather-duster stoutly and advanced into the young inventor's laboratory.

"Don't be afraid, Mrs. Baggert," said Tom laughingly. The youthful genius stood directly in front of a large black box, whose front was covered with small light bulbs that flashed on and off, on and off, like the marquee of a Broadway playhouse. "This is just my latest invention."

"Tom calls it his 'brain,'" said Mr. Barton Swift, Tom's father, as he also entered the laboratory. "Though as to why he has put so many light bulbs on it, even I am hard put to say." The elder Swift, a famous inventor in his own right, gazed at his son with fatherly pride.

"Each and every time a light flashes," pointed out Tom brightly, "an electrical switch inside this box is closed, while the 'brain,' as father calls it, decides on the answer to an important problem. I believe that this machine will be able to give such answers at a very great speed."

"Speed may be just the answer, Tom, if this letter is correct." Mr. Swift came forward, with an envelope in his outstretched hand. "It is from the War Department, in our nation's capital, asking your aid in a problem of great urgency."

"When Washington calls, it must be serious indeed," remarked Tom. "I suppose I should offer my services as soon as need be."

"Will you fly there in your airship, the *Red Cloud*, or travel to Washington in your amazing flying boat, the *Winged Arrow*?" queried Mr. Swift, referring to several of Tom's successful and famous inventions.

"No, father," replied the boy genius, making his mind up quickly. "I will ask Ned to join me, and we can go in my Air Scout. It is able to land 'smack' in front of the Capital steps, you know, and so will save us time."

"Well, I'll make up some sandwiches, and a bottle of milk, for you two boys to take along with you," Mrs. Baggert said, as she hurried off to her kitchen.



AMID THE ROAR OF THE POWERFUL AEROPLANE MOTORS, TOM HAD BUT A FEW MOMENTS TO SOLVE THE PUZZLE OF THE MYSTERIOUS RADIO BEAMS.—Page 198  
*Tom Swift and His Wizard Brain.*



"WELL, NOW, GENERAL," SAID TOM SWIFT, "I'VE GOT THE ANSWER TO YOUR PROBLEM. I'VE BEEN THINKING ABOUT IT FOR A FEW DAYS, AND I'VE FOUND THE SOLUTION."

## SPERRY UNIVAC IN THE EW SYSTEMS BUSINESS

Tom Swift could get important facts, because few expected such facilities in one so young. Tom was always pointed to this approach. But more important, he was creative in his solution to the problem he and his friends faced.

It should hardly be surprising to find Sperry Univac in a position of applying its technologies to the world of electronic warfare. We have been applying our technological abilities to customer requirements for over 20 years. One of the reasons our facilities continue to be sought by the customer with which we apply these technologies is the belief that our EW specialties can be a valuable asset to your operations in the area of:

- Airborne EW Systems
- Surface EW Systems
- Submarine EW Systems
- Forward Area Warning Systems
- Command and Control Systems
- Engulfable EW Systems
- Ground Operations
- EW System Installation and Evaluation
- Intelligence Data Handling Systems

The benefits of such systems to our customers have demonstrated their unique precision, reliability and cost effectiveness. The method by which Sperry Univac can help customers realize these benefits involves our disciplines in design, test, development, production, maintenance, and operational support.

Development is our forte. But it is especially critical to the area, because the cost of electronic technology is so high. In its earliest days, we worked as an "E" team on special assignments. Because we have been performing design, test, production and customer support for over 20 years, "what we know, we know" is still our operating philosophy.

The application and advantages of our specialized technologies have resulted in the greatest benefits of the area. For the EW systems, this combined technology has very definite benefits, based on the capabilities of ESM, the speed and flexibility of our digital

company and the designed functionality of our software. It is enhancing the overall effectiveness of the system to a great degree. It is a great technology. This can be seen and felt in the operation of major EW systems, both military and commercial.

Available in a major factor is a system's operational capability and life-cycle cost. We believe that correct system design can be accomplished at the time of the design, so as to reduce delays in service and prevent, as well as simplify, system architecture and reduce parts. Available factors related to the operation are based on maintaining all elements of a proposed system on the SPERRY UNIVAC\* command, control, and handling. The same process is applied to the development of operational software. Again, cost, reliability, and life-cycle support of operations are the kind of support factors that we provide to customers in 20 years of building

Sperry Univac has proven capabilities in overall system design, production, test, and support. We have a solid record of performance and a strong track record in electronic warfare. Because of this, we are now expanding our capabilities in the area of EW systems. We are now expanding our capabilities in the area of EW systems. We are now expanding our capabilities in the area of EW systems. We are now expanding our capabilities in the area of EW systems.

SPERRY UNIVAC  
A Division of Sperry Rand Corporation

## MULTI-THREAT AND REAL-TIME CAPABILITIES IN SOFTWARE AND SIMULATION

Threat bands tend to rise in frequency. The use of IR and EO spectra is on the increase. The utilization of monopulse emitters tends to generate increased interception immunities. The entire EW world is becoming more complex, more difficult to handle.

By deploying an EW system that integrates sensors (or transmitters) and digital processing, it is possible to equip a platform with threat-reactive *growth* capability. The installed system can be re-programmed to meet new challenges, rather than partially or totally replaced. Since the function of the system is modulated by the threat environment, the system can be made capable of recognizing and processing changing threat modes without extensive structural change or expensive re-programming.

Additionally, the system handles threat information in real-time, thereby fulfilling the original function of supplying the command decision-maker

with time and knowledge.

Real-time has always been a Sperry Univac capability. Just as in our other operating systems, we can produce EW suites that operate successfully in a real-time mode. To a large degree, all of these capabilities subsume from the operational software.

Sperry Univac is in a pre-eminent position to design, implement, test, and certify EW mission-oriented software, because of our assets and experience. Again, people are the foundation: Sperry Univac has over 400 experienced tactical software engineers involved in its programs. One on-going program in which we participate is the operation of a fully-developed military computer compilation facility, in connection with our ADP advisory and software management roles.

We also operate a total wrap-around simulation facility for EW work, utilizing a SPERRY UNIVAC® 1108 computer system.

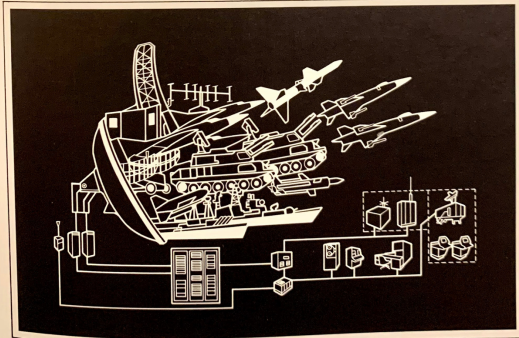

7

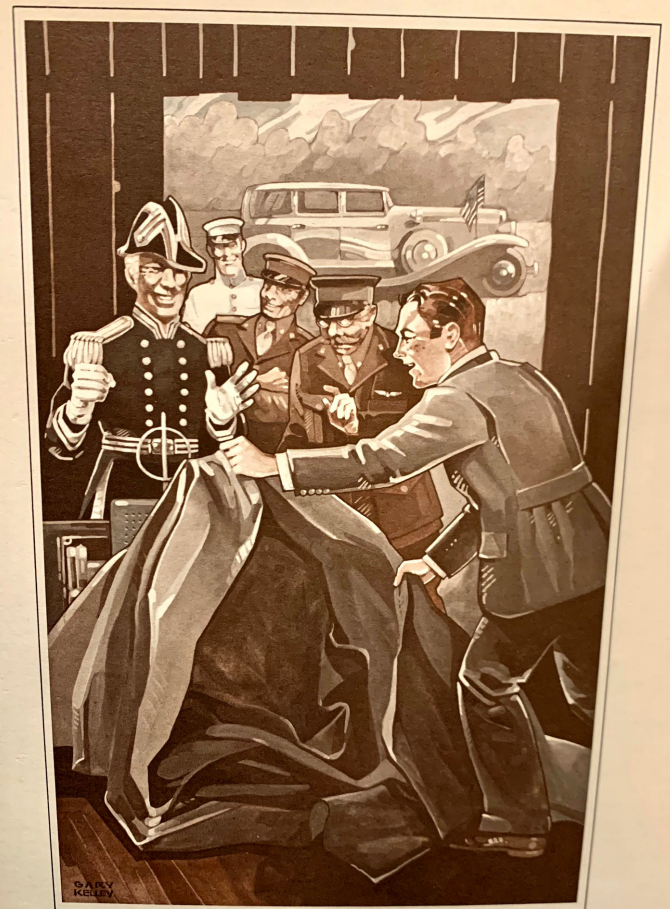

"AND NOW, GENTLEMEN," SAID TOM REVEALINGLY, "HERE IS THE DEVICE THAT WILL MAKE AMERICA SAFE FROM THE ELECTRONIC PERILS OF ITS FOES!" — Page 76  
Tom Swift and His Electrollogical Sensatometer

The following briefings have been prepared by Sperry Univac Defense Systems, to acquaint you with our capabilities and experience in electronic warfare systems. We'd appreciate the opportunity to present one or more of them to you and your group. Please check those areas of major interest to you, then fill out the card and use the outer envelope to return it to us. We'll contact you to schedule the presentations at your convenience. In addition, we'll send along your copy of our new Electromagnetic Spectrum Chart, for you to use and enjoy. We look forward to hearing from you.

### SPERRY UNIVAC DEFENSE SYSTEMS ELECTRONIC WARFARE BRIEFINGS

I'd like to hear what Sperry Univac has to say about the following areas:

- Electronic Support Measures Systems (30 minutes)
- Simulations for Electronic Warfare (45 minutes)
- Development of Tactical Electronic Warfare Systems - Lessons Learned (15 minutes)
- Electronic Warfare Range Automation (45 minutes)

My name is \_\_\_\_\_  
 Title \_\_\_\_\_  
 Organization \_\_\_\_\_  
 Address \_\_\_\_\_  
 Call me at \_\_\_\_\_  
 Number of People in my Group \_\_\_\_\_

I have other questions I'd like to ask now. Please have a Sperry Univac Defense Systems representative contact me directly.

NOTE: Don't forget to send my copy of the new Electromagnetic Spectrum Chart. Thanks.

Signature \_\_\_\_\_

**SPERRY UNIVAC**

